



A Donaldson Company

A WORLD LEADER IN FUME
EXTRACTION TECHNOLOGY

PrintPRO Oracle DS

Last Updated on 13.04.2021



The complete, high performance global fume extraction solution for dye sublimation printers.

The PrintPRO Oracle DS is BOFA's mid range of fume extraction and filtration system. The PrintPRO Oracle DS has been purposely designed to filter the fumes generated from dye sublimation printers and combines extremely large filter capacity with high airflows and pressure.

This combination makes it ideal for heavy duty applications that generate large amounts of particulate and gaseous organic compounds. This system benefits from automatic flow control, which enables the end user to set the required airflow for the application. The unit will then maintain this airflow throughout the life cycle of the filters.

The additional feature of BOFA's 'easi-seal' filter location mechanism makes filter change easy, quick and safe. A truly state of the art laser fume purification solution.

Technology



HEPA filter



Automatic flow control (AFC) technology



Reverse flow air (RFA) technology



Advanced carbon filter (ACF) technology



ProTECT service plan



SureCHECK quality standard

Key features of the PrintPRO Oracle DS

Hydrophobic HEPA Filters
Standard

Filters with long life and low replacement cost
Standard

Automatic fluid drain
Standard

VOC gas sensor (Volatile Organic Compound)
Optional

Filter change / system fail signal
Optional

Turbines with high airflow and pressure
Standard

Automatic flow control system
Standard

Fluid collection tray
Standard

Remote stop / start interface
Optional

2 x sponge filter version
Optional

Contact BOFA at <https://bofainternational.com/en/contact/>

<https://bofainternational.com/en/portal/datasheets/printpro-oracle-ds/>







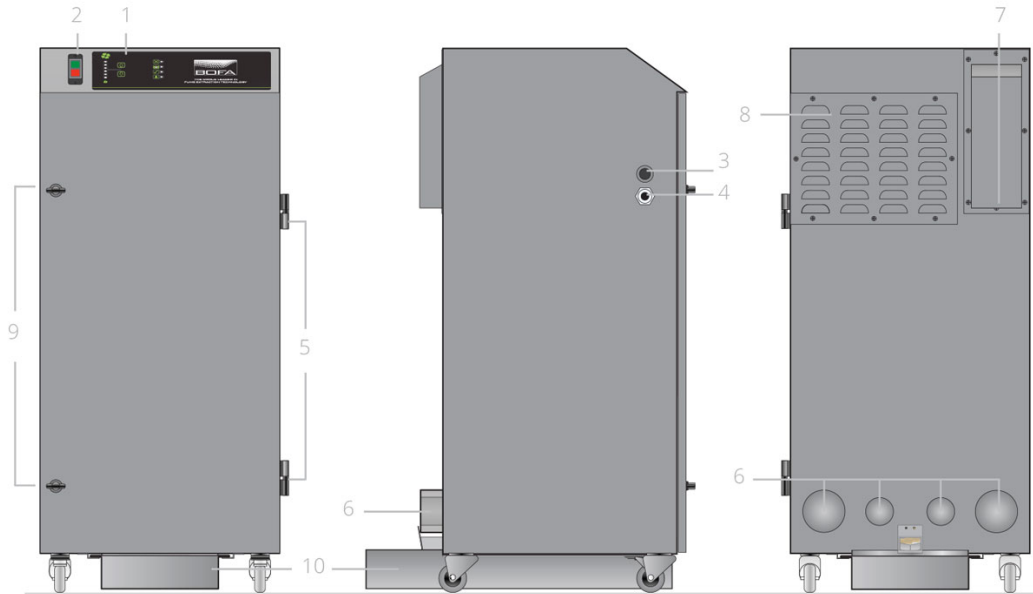

Technical specification

- | | | | |
|--|--|-------------------|-----------------------------|
| 1. Unit / filter condition display
- automatic flow control | 2. On / off switch | 3. Power cable | 4. Signal / interface cable |
| 5. Door hinge | 6. Hose inlet connections -
75mm / 50mm | 7. Exhaust outlet | 8. Motor cooling inlet |
| 9. Door latch | 10. Drain valve | | |



Airflow through filters

-  Chemical filter
-  HEPA filter
-  Sponge filter
-  Clean air
-  Contaminated air
-  Particulate

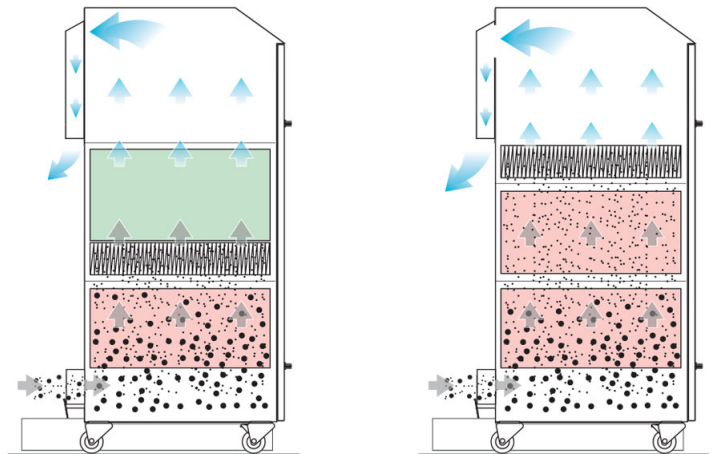

Technical data

	230V	115V
Dimensions (HxWxD)	975 x 450 x 515 mm	38.38 x 17.71 x 20.27"
Cabinet construction	Brushed stainless steel	Brushed stainless steel
Airflow / pressure	380m ³ /hr / 96mbar	223cfm / 96mbar
Electrical data	90 - 257v Single-phase 1~ 50/60Hz Full load current: 12.5 amps / 1.1kw	90 - 257v Single-phase 1~ 50/60Hz Full load current: 12.5 amps / 1.1kw
Noise level	< 60dBA (at typical operating speed)	< 60dBA (at typical operating speed)
Weight	65kg	143.3lbs

Technical data

Approvals

UKCA and CE

UKCA and CE

HEPA filter specifications

Surface media area	7.5m ² approx (80.7 ft ²)
HEPA filter media	Hydrophobic borosilicate
HEPA media construction	Maxi pleat construction with glue bead spacers
Filter housing	Zintec mild steel
Filter efficiency	99.997% @ 0.3 microns

Sponge coalescent filter specifications

Foam media	58 grade open cell foam
Dimensions	375 x 385 x 150

Gas filter specifications

Filter housing	Zintec mild steel
Treated activated carbon	14kgs (30.8 lbs)

Unit part numbers

Model	Voltage	Part no.
PrintPRO Oracle DS (foam + hydrophobic HEPA + gas) Stainless steel	257V	L3442A
PrintPRO Oracle DS (2 x foam + hydrophobic HEPA) Stainless steel	257V	L3342A

Options

Model	24V stop / start	Filter change / system failure signal	VOC monitoring
PrintPRO Oracle DS (foam + hydrophobic HEPA + gas) Stainless Steel	A2001	A2002	A2003
PrintPRO Oracle DS (2 x foam + hydrophobic HEPA) Stainless Steel	A2001	A2002	A2003

Replacement filter part numbers

Model	Sponge filter	Gas filter	Hydrophobic HEPA filter
Optional PrintPRO Oracle DS (foam + hydrophobic HEPA + gas)	A1030387	A1030247	A1030220
PrintPRO Oracle DS (2 x foam + hydrophobic HEPA)	A1030219	N/A	A1030220

Datasheet correct at time of publishing.

Where applicable, the carbon used in BOFA units is capable of removing a wide range of VOC's, however it is the responsibility of the user to ensure the carbon is suitable for their application. For specific applications, please contact us for details.

Think before you print! Please consider the environment before printing this document.

