



A Donaldson Company

A WORLD LEADER IN FUME EXTRACTION TECHNOLOGY

FumeCAB 1000 iQ ESD

ELECTRONICS, PHARMACEUTICAL & MEDICAL

Last Updated on 12.04.2021



The complete cabinet fume extraction solution for a broad range of anti static applications.

Partial enclosures are becoming the recommended extraction option for a variety of applications. Government bodies, including the HSE in the UK are now making direct reference through guidance documentation such as the new HSG258 to their use.

The FumeCAB 1000 iQ ESD integrated filtration system has been designed to ensure compliance with the latest regulations.

BOFA's iQ Operating System and ultra-bright slimline energy saving LED lights come as standard, making this system an ideal choice of fume extraction for a wide variety of anti static applications. It provides users with a anti static working environment.

More information about the [Intelligent Operating System \(iQ\)](#).

Technology



Intelligent Operating System (iQ)



HEPA filter



Automatic flow control (AFC) technology



Reverse flow air (RFA) technology



Advanced carbon filter (ACF) technology



Patented technology



ProTECT service plan



SureCHECK quality standard

Key features of the FumeCAB 1000 iQ ESD

Certified to BS 7989:2001 - recirculatory filtration fume cabinet specification Standard

Reverse flow filter technology Standard

Energy saving ultra-bright slim line LED lighting Standard

Combined HEPA / gas filter incorporating ACF technology Standard

Anti static Standard

Ensures operational compliance with HSG258 guidelines Standard

Automatic flow control system Standard

Twin coated anti UV / anti splash protective polycarbonate visor Standard

Filters with long life and low replacement cost Standard

Real time airflow reading Standard

Contact BOFA at <https://bofainternational.com/en/contact/>

<https://bofainternational.com/en/portal/datasheets/fumecab-1000-iq-esd/>



Independent filter condition monitoring, display and warnings

Standard

'Run safe' operation

Standard

Large working area

Standard

VOC gas sensor (Volatile Organic Compound)

Optional

Stand

Optional

High contrast display

Standard

Remote diagnostics via USB

Standard

Side entry blind grommets for equipment access

Standard

UV lighting

Optional

Optional filter medias

Optional

Technical specification

1. iQ display

2. On / off switch

3. Filter compartment latches

4. Cable entry grommet

5. Anti static transparent visor

6. Transparent visor hinges

7. Power cable inlet

8. Internal LED lighting

9. Exhaust outlet

10. Cooling air inlet

11. Standby button

12. Anti static mat

13. Optional internal UV lighting

14. Optional stand



Front



Left Side / Internal work area

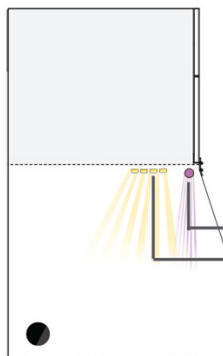

Back

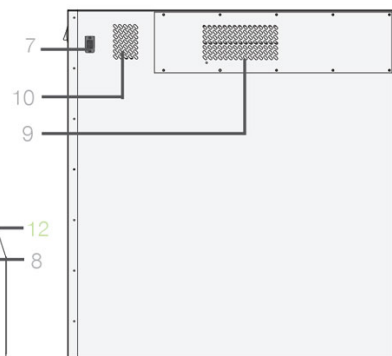

Internal work area and stand

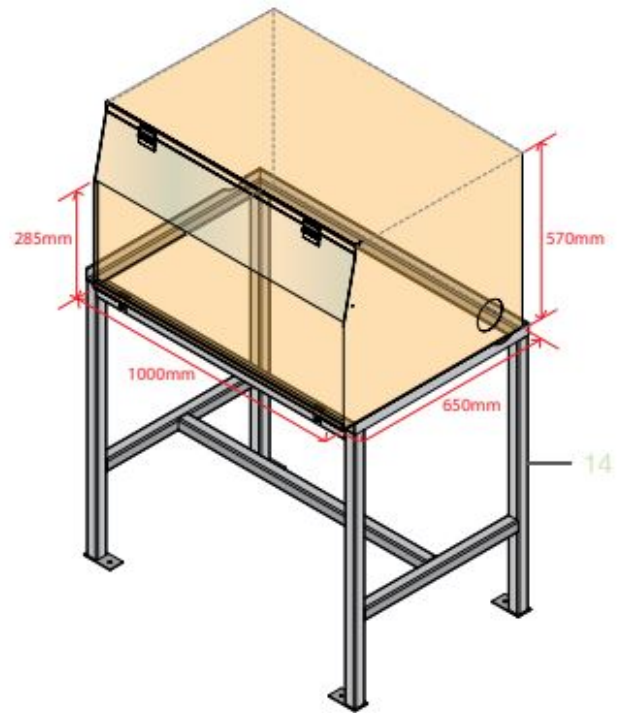

Airflow through filters

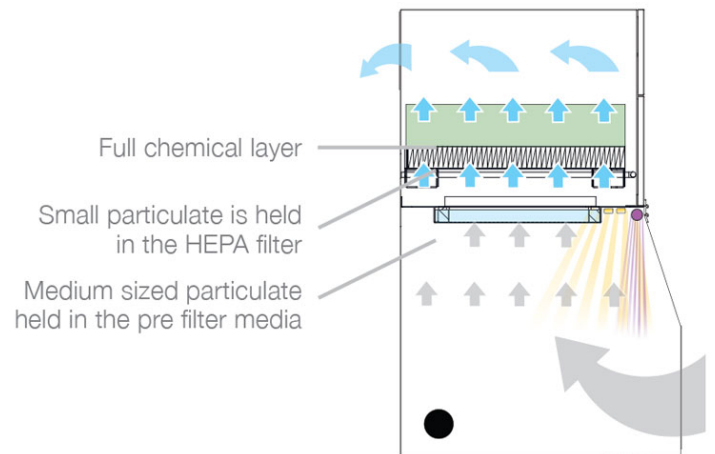
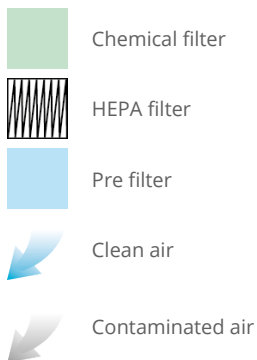

Technical data

	EU	US
Dimensions (HxWxD)	1026 x 1000 x 660mm	40.3 x 39.4 x 26"
Opening dimensions (HxW)	285 x 1000mm	11.2 x 39.4"
Cabinet construction	Powder coated mild steel	Powder coated mild steel
Face velocity	0.4m/s (410m ³ /h)	78.7ft/min
Max face velocity	0.6m/s (616m ³ /h)	118ft/min
Electrical data	230V 50/60Hz	115V 56/60Hz
	Full load current: 6 amps	Full load current: 10 amps
Noise level	< 58dBA at typical operating speed	< 58dBA at typical operating speed
Weight	123kg	271.2lbs
Exhaust outlet (Optional)	150mm	150mm

Technical data

Approvals

UKCA and CE

UKCA and CE

Pre-filter specifications

Filter media construction	Borosilicate pleat
Filter housing	Cardboard
Filter efficiency	99% @ 0.3 microns

Combined HEPA / gas filter specifications

HEPA filter media	Borosilicate
HEPA media construction	Maxi pleat construction with glue bead spacers
Filter housing	Zintec mild steel
Treated activated carbon	17kgs (37.4 lbs)
Filter efficiency	99.997% @ 0.3 microns

Optional stand specifications

Dimensions (HxWxD)	943 x 1029 x 669mm / 37.1 x 40.5 x 26.3"
Stand construction	Powder coated mild steel

Unit part numbers and options

Model	Voltage	Part no.	Optional VOC monitor	Optional UV lights	Optional stand
FumeCAB 1000 iQ ESD Powder coated	230V	E2242A1000	A2003	A2010	A1060054
FumeCAB 1000 iQ ESD Powder coated	115V	E2241A1000	A2003	A2010	A1060054

Replacement filters

Pre-filter	Combined filter
A1030249	A1030250

Datasheet correct at time of publishing.

Where applicable, the carbon used in BOFA units is capable of removing a wide range of VOC's, however it is the responsibility of the user to ensure the carbon is suitable for their application. For specific applications, please contact us for details.

Think before you print! Please consider the environment before printing this document.

